

POST PROCESSING SOFTWARE

The post processing software is a Windows based software designed and developed for LS-series handheld 3D laser scanners, it is also compatible with third-party device for point cloud processing.

The software is a powerful point cloud post-processing software that is supported by the system. The software has rich functions and is easy to operate. It supports loading and exporting point clouds in various formats. It can achieve a series of functions such as one-click point cloud denoising, point cloud splicing, shadow rendering, coordinate transformation, automatic horizontal plane fitting, automatic point cloud data report generation, forward photography and point cloud encapsulation.



ADVANTAGES

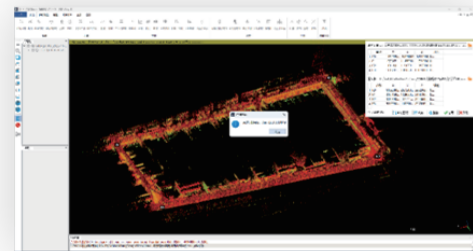

Control Point Conversion

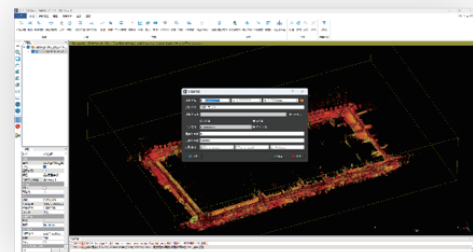

Multi Coordinate System Conversion

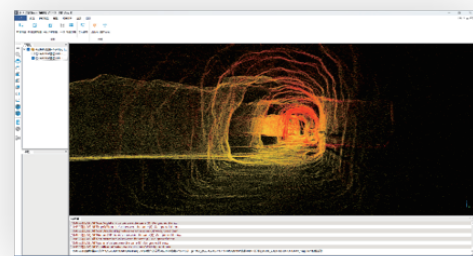

X-Ray Display Mode

PARTIAL FUNCTION DISPLAY

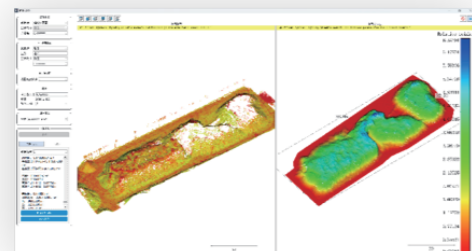

Measurement of Pile Volume

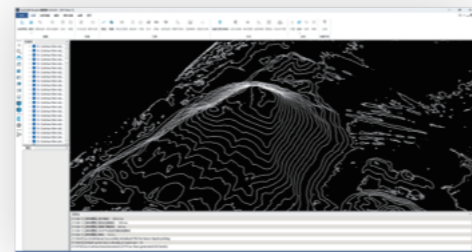

Creating Contours

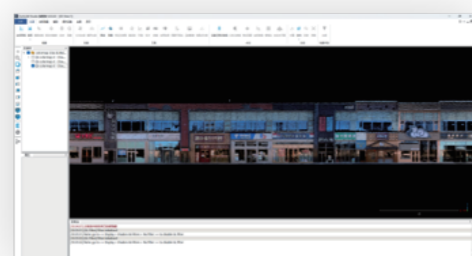

Color Point Cloud

SPECIFICATIONS

Laser Scanning System

Ver.2023.09.19

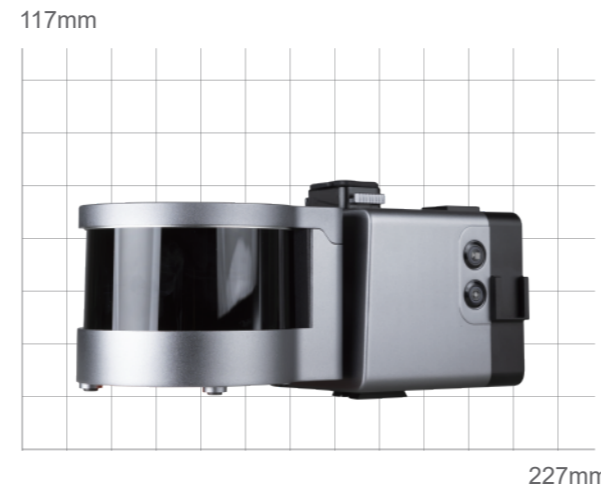

Weight: 1.35 kg
Size(L x W x H): 227mm x 105mm x 117mm

Physical

Weight	1.35 kg (handhold parts)
Working Temperature	-35°C~+60°C
Storage Temperature	-40°C~+85°C
SSD	500GB (expandable)
IP Code	IP54 waterproof and dustproof

Performance

Relative Accuracy	1cm (peak)
Scanning Range	120 meters
FOV(Field of Scan)	360°x 285°
Scanning Speed	320,000 Points per second
Scan positioning	SLAM (No need for GPS)
Solution method	Hybrid algorithm
Live preview	Mobile APP

Laser

No. of Laser Sensor	1
Safety Level	Class I
Laser Lines	16-line

Battery

Type	Lithium ion battery (hot swap)
Capacity	98Wh/6.8Ah
Voltage	14.4V
Battery Time	4 hours
Charging Temperature	0°C~+40°C
Operating Temperature	-20°C~+50°C

SinoGNSS[®]
By ComNav Technology Ltd.



LS300 Laser Scanning

High Precision Positioning Empowers A Digital Era

ComNav Technology Ltd.

Building 2, No. 618 Chengliu Middle Road,
201801 Shanghai, China
Web : www.comnavtech.com
Email : sales@comnavtech.com
Tel : +86 21 64056796
Fax : +86 21 54309582



NEW WAY OF MOBILE MEASUREMENT

Capable of multiple scanning modes, the LS300 Laser Scanning System is also suitable for a wide variety of applications. The GNSS module can be switched quickly, enabling scanning of the WGS84 coordinate systems point clouds, with absolute accuracy of about 2 cm with mapping software.

HANDHELD RTK KIT



Size	33x26x16cm
Material	Aviation Aluminum、ABS
Weight	167g
Install Time	<30s
Positioning Accuracy	Horizontal Around 1cm Altitude Around 2cm

BACKPACK KIT



Size	33x26x16cm
Material	Aviation Aluminum、ABS
Weight	2.21kg
Install Time	<1min

CAR MOUNT KIT



Size	34x25x16cm
Material	Aviation Aluminum、ABS
Weight	1.9kg
Install Time	<3min

DRONE KIT



Size1	Host CPU18.4x13.4x4.8cm
Size2	Scanner 13.5x12.5x10.2cm
Material	Aviation Aluminum、ABS
Weight	270g
Install Time	<3min
Supporting Series	Dji M300

SPECIFICATIONS

The LS300 Laser Scanning System uses SLAM technology (simultaneous localization and mapping), which is real-time positioning and mapping technology. It does not rely on GNSS positioning, and performs self positioning and incremental 3D mapping in unknown environments, including indoors and outdoors. Its lightweight design makes measurement work so easy. With synchronous data acquisition, simply walking around can complete the information data collection. ComNav Technology is committed to providing user-centered 3D laser mobile scanning measurement system product solutions, bringing users a better work experience.

Handheld Terminal



Excellent Performance



Color Screen



Diverse System Platform



Hot Swappable Batteries



HSL Hybrid Solution



APP Real Time Preview



Anchor Point Process

FEATURES

Excellent Performance

LS300 configures a rotating laser sensor probe with 120 meters working distance; sample rate up to 0.32M points per second; Large field of scan up to 360°x285°; Point accuracy up to 1.0cm. (low reflectivity extended-range mode)



HSL Hybrid Solution

The LS300 has a unique hybrid solving technology which can perform post processing for the previous data during the scanning. High precision data collected is more faster and efficiency ever before.



Color Screen

A new color status display screen with a larger size supports more information display as well as operating instructions which making it easier to use and getting started.



APP Real Time Preview

During operation, APP can browse point cloud data in real time which support multiple browsing interaction modes and more humn-computer interaction content.



Diverse System Platform

Multiplicity external ports can easily interface with third-party device systems, providing diverse way of collaborative work, bringing more possibilities for expanding application scenarios and methods.



New Visual Experience

The LS300 has more excellent point cloud color function which provides users with clear immersive color effects, clearer details, more bright colors and more realistic effects.



Hot Swappable Batteries

The LS300 adopts two batteries uninterruptible redundancy design, supports hot swapping and replacement of batteries, and has this technical patent.



Anchor Point Process

An anchor point solution function ensures accuracy and stability when scanning data indoors and outdoors with large ranges, low characteristics, and high difficulty. During the data post process, input the absolute coordinates of control points, and control points can perform overall data adjustment on the data to obtain high-precision scanning results data.



APPLICATION

